

Your Guide to Joint Replacement

What's Inside

| | |
|--------------------------------------------------------------|-----------|
| About this Guide | 3 |
| Preparing for Surgery | 4 |
| Preparing your home..... | 6 |
| What Your Healthcare Providers Need to Know | 8 |
| Your pre-surgery health record..... | 9 |
| Packing your bag..... | 10 |
| Surgery and Recovery | 11 |
| Understanding anesthesia..... | 12 |
| Pain management..... | 14 |
| Using opioid medications safely | 15 |
| Medication tracker | 16 |
| Controlling pain with RICE | 17 |
| Preventing complications | 18 |
| Physical and occupational therapy..... | 22 |
| Assistive devices..... | 23 |
| Preparing to go home..... | 25 |
| Intimacy after surgery..... | 26 |
| Knowing when to call the doctor | 29 |
| Survey notice..... | 30 |

About this Guide

Now that you have decided to have joint replacement surgery, we want to help you learn more about:

- The best way to prepare for your surgery
- What to expect before, during, and after surgery
- How to recover as quickly as possible

Plan to get the most from this guide by:

- **Writing in it.** This guide is designed to help you keep track of information, progress, and questions.
- **Sharing it with your partner in healing.** A partner in healing is a family member or friend who will help you for a few days when you go home from the hospital. Help your partner in healing understand how to best support you at each phase of your care.



Research tells us that patients who attend a pre-surgery class and review printed materials do better after having joint replacement surgery. We strongly recommend all joint replacement patients participate in a free education session before their surgery. It is recommended that you attend a class at the hospital or facility in which you plan to have your surgery.

Register online by visiting:

<http://intermountainhealthcare.org/tjc>

Or by scanning the QR code:



Preparing for Surgery

Being in good health lowers your risk of complications during and after surgery. Certain health risks can increase your chances of complications. It is important to work on these health risks before having joint replacement surgery.

- If you smoke, chew tobacco, or vape, QUIT!**
You need to quit smoking one month before your surgery. Do not restart after your surgery.
- Get control of any other health conditions you have.** Managing your blood pressure, blood sugar, and other conditions is essential to a successful surgery. If you have diabetes, make sure your A1c is less than 8.0 to help your wound heal faster.
- DO NOT USE alcohol or street drugs.** These substances can seriously impact how you react to anesthesia and medications.
- If you are overweight, try to lose a few pounds.** For every pound you lose, you take pressure off of your joints, which will make it easier to get around after surgery. Eating **more** fruit, vegetables, and whole grains and **less** fat, sugar, and red meat will help speed up your recovery.
- If you need any invasive medical or dental procedures, ask your surgeon how far in advance you should schedule these.**
 - **Invasive medical procedures.** Any procedure that requires a cut in the skin can introduce bacteria (germs) into your body. This puts you at higher risk for an infection that could impact your new joint.
 - **Dental procedures.** Just like medical procedures, dental cleaning and having root canals, a tooth pulled, or a crown exposes you to bacteria.
- Talk to your surgeon BEFORE getting a steroid injection** into the joint being replaced. This can increase the risk for infection and related complications.
- If you take any opioid pain medications, try to cut back.** Decrease your use of these medications as much as possible so your care team can effectively control your pain after surgery. If your body is tolerant of high doses of pain medication, discuss this with your surgeon. Your pain may be more difficult to control.

Things that may delay your surgery

There are several things that may cause your surgery to be rescheduled. They include:

- Eating or drinking after a specified time
- Any respiratory (airway or lung) illness
- Any open wounds or breaks in the skin on the area to be operated on.
- Fever of 101°F (38.3°C) or higher
- Failure to stop taking medication as directed by your surgeon before surgery (for example, aspirin or other blood-thinning medications)

Getting your body ready for surgery

Studies show that your level of function before surgery impacts how well you do after surgery.

Specific exercises

Ask your surgeon about specific exercises you can do to help you prepare for your joint replacement surgery. Specific strengthening exercises may help prevent blood clots and help to strengthen muscles around the joint to be replaced

Your surgeon or therapist will recommend exercises depending on your specific needs.

General exercises

General strengthening exercises include biking, swimming, walking, and water aerobics. Try to exercise at least 30 minutes a day, 5 days a week to improve your health and strength before surgery. Even if your surgery is only a week or so away, starting exercises now can help give you a head start on your rehabilitation and recovery afterward.



"My doctor told me that doing regular exercise could make it easier for me to come out of anesthesia after surgery. Plus, if I lost a few pounds, she said that I would heal faster. That was all I needed to hear to join a water aerobics class."

— Phyllis, Knee Replacement Patient

Preparing your home

When you come home after surgery, you will need to be extra careful to prevent falls and injuries while you recover. There are small changes you can make at home now to make your recovery as safe and speedy as possible. Practice doing your daily activities as if you have already had surgery and are not able to use that joint as much. You may find that you need to move items or change things around from your normal routine.

Set up your recovery space

- Leave space around furniture for using a walker, cane, or crutches.
- Place a sturdy chair with arms near a table.
- Ensure that chair seats are high enough to get into and out of easily. Add cushions if necessary.
- Clean and vacuum your house. A clean house reduces bacteria and chance of infection.

Arrange for assistive equipment

- DO NOT expect people to lift or move you** — they could get injured. Use the prescribed assistive equipment instead.
- For patients that are having a hip or knee surgery, plan on needing a front-wheeled walker or forearm crutches. You may also want a raised toilet seat or toilet safety frame and a shower chair.

Reduce tripping hazards

- Remove throw rugs or small objects on the floor.
- Tack down or tape carpet edges.
- Remove clutter.
- Clear pathways of furniture and electrical cords.

Improve lighting

- Use night lights and add lamps if necessary.
- Make sure your stairs and hallways are well lit.

Manage pets

- Make a plan to keep your pets from tripping you once you come home. For example, you could keep pets in a different area of the house or put a bell on each pet's collar to alert you when they are near.
- Consider boarding your pets or having them stay with a friend or family member when you first come home.

Prepare your kitchen and bathroom

- Stock up on supplies and groceries. Prepare and freeze meals ahead of time to warm up while you are recovering.
- Place items where you can easily reach them. (No lower shelves for hip or knee patients and no high shelves for shoulder patients.)
- DO NOT USE step stools.**

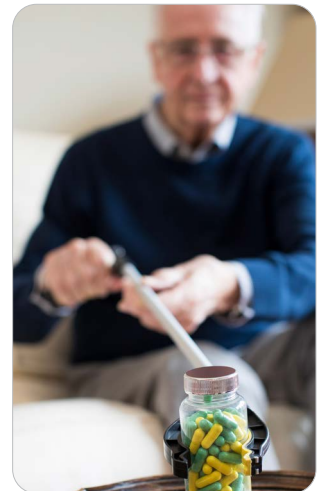

Equipment for home

Pick up the following items before your surgery to have ready when you go home.

- Front-wheeled walker
- Toilet and shower devices
- Dressing aids
- Crutches
- Reacher device

Tips for creating a safe bathroom after surgery

Check the items in the illustration below that apply to your situation.

- Use an **elevated toilet seat or toilet safety frame** to raise the height of your toilet and steady yourself when standing up from the toilet.
- Install a **hand-held shower hose and single-lever water mixing faucet** for better temperature control.

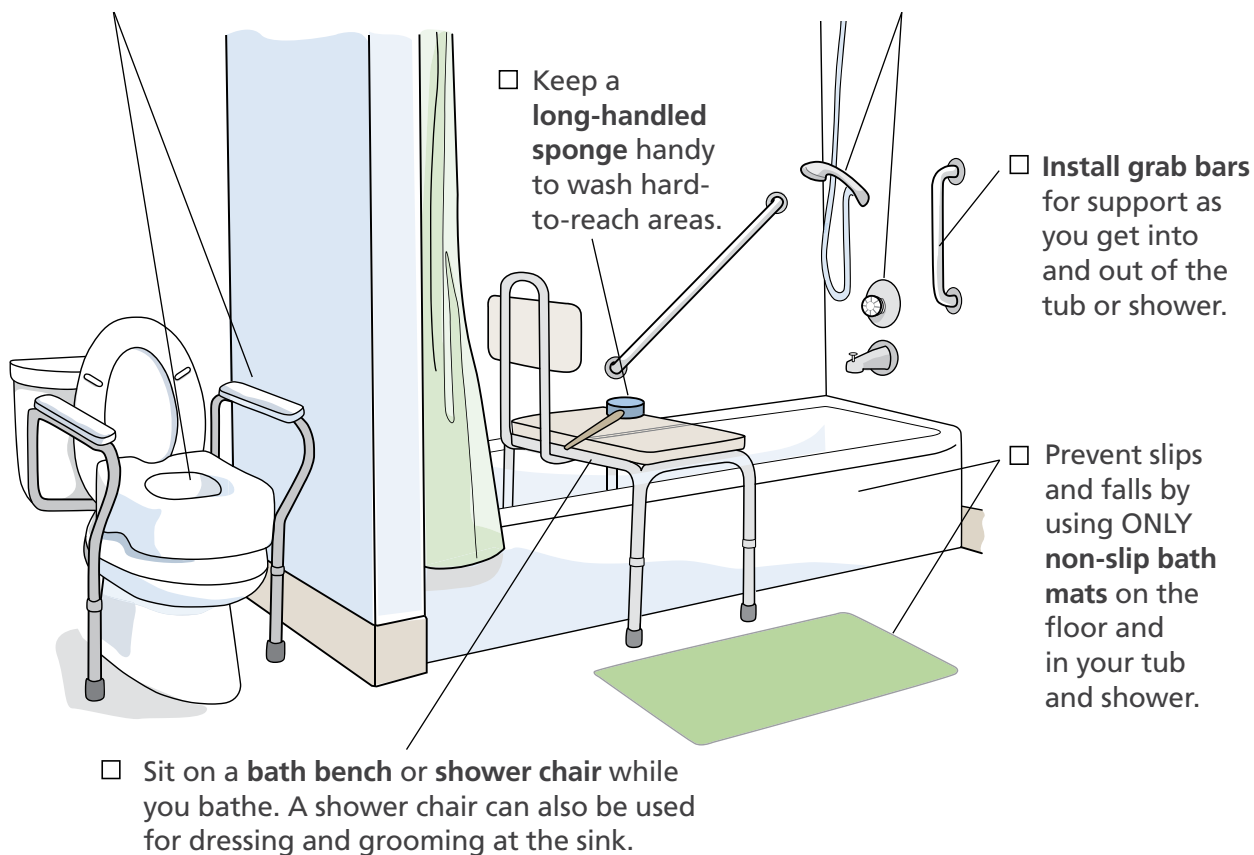

Other safety considerations include keeping your hot water heater set at no more than 120 degrees, putting daily-use items within reach, and not using bath oils in the tub or shower.

Grab bar guidelines

If you decide to install grab bars for general safety, follow these guidelines:

- Consider a professional installation for wall-mounted grab bars.
- Use grab bars that are 1 ¼ to 1 ½ inches in diameter.
- Choose a bar with a textured surface to make it easier to grip.

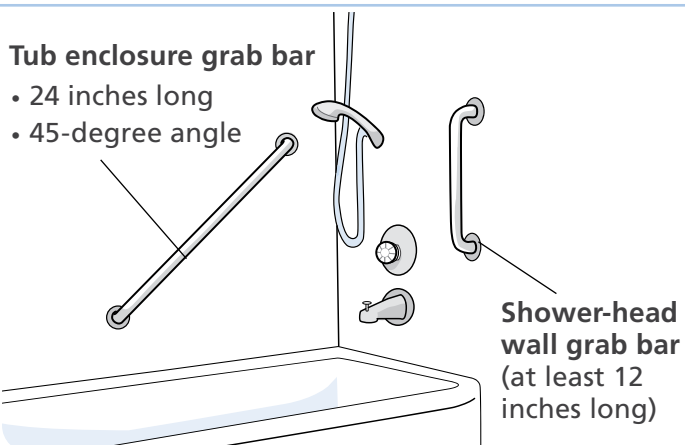

What Your Healthcare Providers Need to Know

The more your healthcare providers understand your current condition, the better they can reduce the risk of surgical complications. The information below explains why your care providers need to learn as much as possible about your medical history and medications.

- **Infections.** A current or past infection on any part of your body can lead to surgical complications. Problems, such as active dental infections or urinary tract infections, should be diagnosed and treated before surgery.
- **History of heart problems.** Discuss these with your primary care doctor and cardiologist (if you have one) so that your care team can help prevent heart-related complications.
- **Other medical conditions.** Your care team needs to know if you have ever had certain conditions or allergic reactions. These include diabetes, a transplant, a bleeding disorder, deep vein thrombosis (DVT), pulmonary embolism (PE), sleep apnea, complications with anesthesia, latex allergy, or a pacemaker.
- **Current skin conditions.** Open sores, areas of infection or irritation, and old incisions can increase the risk of infection, slow wound healing, and cause other problems. This is especially true for the skin around the incision site. Tell your surgeon about skin issues—wounds, abrasions, skin injuries, and any other changes—that occur between your last office visit and the day of surgery.
- **Your medications.** Some medications can cause problems or slow your recovery when taken together. **Give your care providers a complete list of all medications you take, including vitamins, herbal remedies, or supplements.**
- **General physical health.** Your surgeon may require a physical exam, blood work, and other pertinent tests.
- **Quality surveys.** You may be asked to complete surveys that measure your ability to function before and after surgery.



Notes

Your pre-surgery health record

Gather the information below before your surgery. Your healthcare team will need this information before your surgery. Having this information ready will make the process much smoother. You can also request a list of your medications from your primary care doctor.

Check the items below that apply to you.

- I do not currently smoke, vape, chew tobacco, or use nicotine products.
- I have had the pre-surgical tests my doctor ordered, such as ECG, blood work, and x-rays.
- I have not traveled outside of the country in 30 days.

I currently have the following:

- Diabetes.
- Obstructive sleep apnea.
- A breathing disorder or a need to use oxygen at home.
- A pacemaker or defibrillator. If so, record the make and model: _____

Date of the last check to ensure proper operation and charged batteries: _____

- A heart stent.
- History of DVT or PE (including in family).
- History of chronic infection such as MRSA, VRSA, VRE, C-diff, or ESBL.
- Allergies to medications, food, materials, or other. If so, list your allergies below:

- An advance directive (check all that apply):
 - Power of attorney – POLST (UT)
 - Living will – POST (ID)

List every medication, vitamin supplement, or herbal remedy you take in the space provided.

In the "dose" column, write how much you take. (For example, include the number of milligrams [mg] per pill printed on the pill bottle label, and how many pills you take each time.)

| Prescription medications I take | Dose | How often | Reason |
|---------------------------------|-------|-----------|--------------------|
| Example: Metoprolol ER | 25 mg | daily | for blood pressure |
| | | | |
| | | | |
| | | | |
| | | | |
| | | | |
| | | | |
| | | | |
| | | | |
| | | | |

| Over-the-counter medications I take (including vitamins and herbal remedies) | Dose | How often | Reason |
|------------------------------------------------------------------------------|--------|-----------|--------|
| Example: Fish Oil | 100 mg | daily | |
| | | | |
| | | | |
| | | | |
| | | | |
| | | | |
| | | | |
| | | | |
| | | | |
| | | | |

Packing your bag

Check the items below that you need to pack.

What to bring to your surgery

- Bring *Your Guide to Joint Replacement* booklet.
- A partner in healing who can stay with you until the time of surgery and will be responsible for taking you home afterward.
- A small bag of personal items with:
 - A pair of fully-fitted, non-skid shoes or slippers. You'll need these during therapy.
 - Loose clothing that can fit over bulky bandages and can be easily pulled over your surgical arm or leg.
 - Personal care items such as a toothbrush and deodorant.
 - Your cell phone, e-reader, laptop, or book, if you choose. Don't forget the charger for your electronic devices.
 - Your CPAP and mask, if you use one.
 - A "rescue inhaler," if you use one.
 - A case for glasses, contacts, or hearing aids.
 - Your picture ID and insurance card.
 - A list of all medications you take including herbal supplements and over-the-counter medications.
 - A list of any questions or new concerns you want to discuss with your surgeon or anesthesia provider.
 - A copy of your advance directive form.



What NOT to bring:

- Valuables such as cash or jewelry
- Medications or supplements (unless otherwise directed)

Surgery and Recovery

When you have surgery, your care team can help you determine the best anesthesia for your surgery and health. During surgery, they will perform your joint replacement using best practices of surgical and medical care. After surgery, your pain will be managed and side effects kept to a minimum.



“I really appreciated how carefully the staff explained what I could and could not do when I woke up. I had no idea how the spinal anesthesia would affect me!”

— Joe, Hip Replacement Patient

Understanding anesthesia

Before surgery, you will be given anesthesia, a type of medication that keeps you comfortable during surgery.

There are several types of anesthesia. The type that will be best for you depends on the surgery you are having and your overall health and risk factors. With any type of anesthesia, there may be some side effects or complications (although rare).

What will it feel like when the anesthesia wears off?

When your anesthesia begins to wear off, you may feel tingling or burning as well as aching. **Remember:** You will have pain following a major surgery like this. The goal is to be able to manage your pain so you can rest, heal, and do physical therapy. Also, if you used opioids to manage pain before the surgery, it may make it more difficult to manage your pain afterward.

General anesthesia

Used during many major surgeries, this type of anesthesia affects your entire body and puts you into a deep sleep. It's usually given by injection (shot), gas inhalation, or through an intravenous (IV) catheter inserted into a vein.

Once you are asleep, the anesthesiologist will place a breathing tube down your throat and give you oxygen to assist your breathing during the surgery.

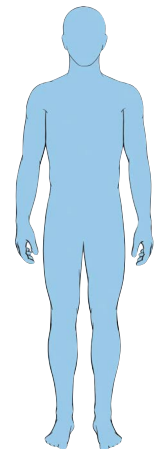

Spinal regional anesthesia

This type of anesthesia is given as an injection before surgery to prevent feeling in the lower part of your body. It will wear off a few hours after surgery.

Regional anesthesia should not affect your breathing or heart rate, so you will be able to breathe and swallow on your own. Because you remain conscious, you will also be given sedatives to make you sleepy.

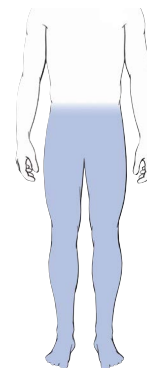

Peripheral nerve blocks

These blocks are a type of local anesthesia used to help with pain control after surgery. A local anesthetic is injected around some of the nerves to the joint being replaced.

A peripheral nerve block can be a one-time injection or an infusion of medication that lasts for several days after surgery. Peripheral nerve block medication provides relief to local pain (a small area near your surgery site). It usually lasts 1 to 3 days.

The shoulder peripheral nerve block numbs your arm. It can temporarily affect your ability to move your arm, wrist, and hand.

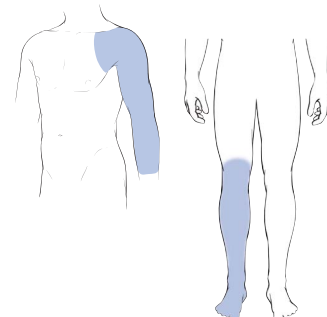

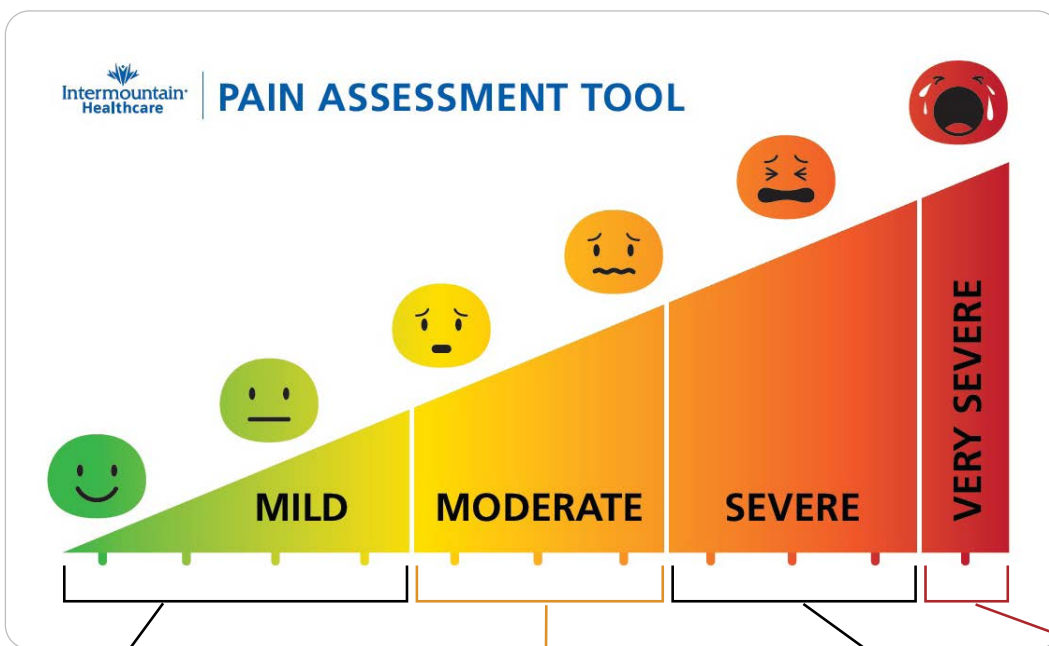

0 No Pain

1 Hardly notice pain
It's mostly uncomfortable

2 Slightly aware of pain
But mostly don't think about it

3 Somewhat aware of pain
Still can take mind off it
Doesn't get in the way of doing things

4 Quite aware of pain
Not as easy to take mind off it

5 Very aware of pain
May get in the way of doing some things
Hard to sleep and rest

6 Hard to take mind off pain
Hard to find a comfortable position

7 Restless
Can't take mind off pain
Can't find a comfortable position

8 Don't want to talk with people or text
Don't want to eat
Can hardly sleep or rest

9 Very hard to talk with people or text
Pain is all you can think about
Sometimes cry out

10 Not at all able to talk with people or text
Not at all able to eat, sleep or rest
May cry out without control

Everyone's ability to tolerate pain is different. You will be asked to rate your pain on a scale of 0 to 10 and identify the type of pain you are experiencing. Your pain should be managed enough that you can rest and do your recovery activities, such as therapy and exercise.



Pain management

How is my pain controlled?

Your pain may be controlled using the **multimodal** [mull-tye-MODE-uhl] approach or other methods. The multimodal approach means using different types of medications that all work to manage pain. It may include the use of one or more of the following medications:

- **Pain relievers**, such as acetaminophen (Tylenol)
- **Non-steroidal anti-inflammatory drugs (NSAIDs)**, including ibuprofen (Motrin, Advil), naproxen (Aleve, Naprosyn), Celebrex, Meloxicam, or Toradol
- **Muscle antispastics**, including diazepam (Valium) and cyclobenzaprene (Flexeril)
- **Nerve pain treatments**, including gabapentin (Neurontin) and pregabalin (Lyrica)

Opioids are potent pain medications with many side effects. The most concerning side effects is respiratory depression (slowed breathing). To stay safe, opioids should only be taken when your pain is not controlled by other non-opioid medication or measures. Opioids should only be taken for a short time on an as-needed basis.

- **Opioids**, including oxycodone (Roxicodone), hydromorphone (Dilaudid), hydrocodone (Norco, Lortab), and tramadol (Ultram)





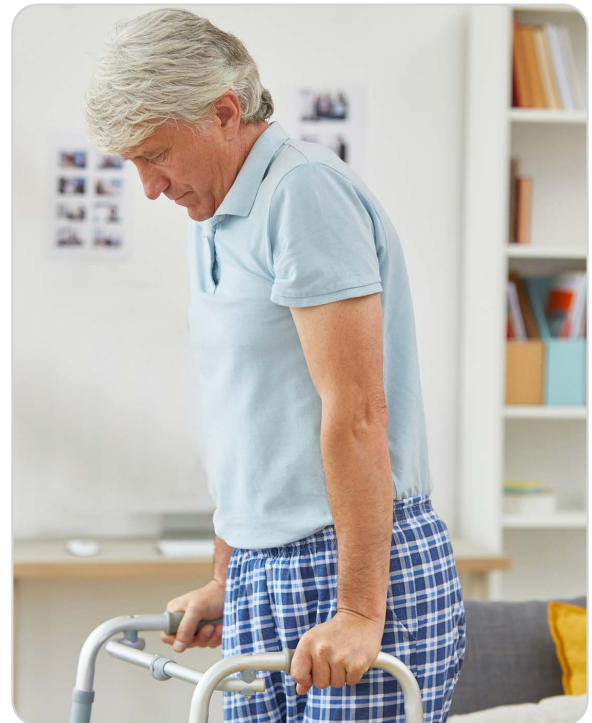



Before taking opioid pain medication

- Reposition yourself in the bed for comfort or sit in the bedside chair.
- Elevate your operative leg or arm above the level of your heart.
- Apply ice
- Get up and move or stretch
- Distraction (music, TV, games)
- Massage, relaxation or meditation techniques



Controlling pain and swelling with RICE

Swelling is a cause of pain. It is best controlled by using the R.I.C.E. method (shown below).

| R. I. C. E. | Rest | Ice | Compression | Elevation |
|--------------------------------------------------------------------------------------------------------------------------|-------------------------------------------------------------------------------|---------------------------------------------------------------------------------------------------------------------------------------------------------------------------------------------------------------|-------------------------------------------------------------------------------------------------------------------------------------------------------|------------------------------------------------------------------------------------------------------------------------------------------------------------------------------------------------------------------------------------------------------------------------------------------------------------|
| Total Knee Replacement  | <p>It's important to let your body rest and heal to help reduce swelling.</p> | <p>Use Ice Packs for 20 to 30 minutes every 1 to 2 hours. Be sure to put a barrier between the ice pack and the skin.</p>  | <p>Use an Ace Bandage or Compression Stockings to provide support and encourage fluid to return to the heart. Follow your surgeon's instructions.</p> | <p>Elevate your leg above your heart (Toes above Nose) to help the fluid to move back to your body. DO NOT place a pillow directly behind the knee — elevate the whole leg instead.</p>  |
| Total Hip Replacement  | <p>It's important to let your body rest and heal to help reduce swelling.</p> | <p>Use Ice Packs for 20 to 30 minutes every 1 to 2 hours. Be sure to put a barrier between the ice pack and the skin.</p>  | <p>Use an Ace Bandage or Compression Stockings to provide support and encourage fluid to return to the heart. Follow your surgeon's instructions.</p> | <p>Elevate your leg above your heart (Toes above Nose) to help the fluid to move back to your body. DO NOT place a pillow directly behind the knee — elevate the whole leg instead.</p>  |
| Total Shoulder Replacement  | <p>It's important to let your body rest and heal to help reduce swelling.</p> | <p>Use Ice Packs for 20 to 30 minutes every 1 to 2 hours. Be sure to put a barrier between the ice pack and the skin.</p>  | <p>The weight of your ice pack should be enough to add compression to your shoulder. Follow your surgeon's instructions.</p> | <p>Sitting upright will help keep your shoulder above your heart and reduce swelling. When sleeping, try to be in a more upright position or at least elevate your head and shoulders with an additional pillow.</p>  |

Using opioid medications safely

Prescription opioids are medicines used to help relieve severe pain. These medicines are an important part of your treatment, but also come with serious risks, such as slowed breathing and possible overdose.

To stay safe

- **Take non-opioid pain medication first.**
- **Never take more medication than prescribed** or take it more often than your healthcare provider tells you to.
- **Don't have someone wake you to take pain medication** or let you take pain medication if you can't stay awake for meals and daily activities.
- **Never use alcohol or street drugs when taking opioid pain medications.** The combination can kill you.
- **Keep medication in the bottle it came in.** The label has instructions and information you need.
- **Never share pain medication.** Don't give your pills to friends or family members, even if the person is in pain.
- **Lock up medications.** Don't keep your pain pills in your medication cabinet where anyone can find them. Dispose of leftover pills safely. Check with your provider or your local police department for safe places to throw away leftover medications.
- Get a prescription for Naloxone from your surgeon or care provider if you are taking opioid medication. Naloxone can help revive you in case of accidental overdose from opioids. Learn more at: utahnaloxone.org

Relieving pain with medication

You can prevent problems and avoid the risk of addiction to pain medications by taking them **exactly** as your doctor directed.

Relieving pain without opioid medication

These options can help you manage pain without opioid medication:

- Cold therapy
- Guided imagery and distraction
- Physical therapy or exercise
- Relaxation or meditation
- Massage
- Spiritual or emotional counseling

Tips for refilling opioid pain medications

To make sure you don't run out of pain medication on the weekend, follow these 2 steps:

- 1 Count how many pills you take each day to see when you will run out.
- 2 Contact your doctor's office at least 48 hours before the date you will need more pills.

Medication tracker

Use the chart below as an example to help you track how much medication you take.

Remember these precautions when taking pain medication:

DO:

- Take non-opioid pain medication first.
- Have someone you trust help you keep track of how many pain pills you take each day.
- Tell your doctor if you still have a lot of pain even after taking your pain medication.
- Tell your caregivers to **CALL 911** if your breathing slows down or stops, or if they can't wake you.
- Tell your caregivers to use Naloxone as directed in case of overdose.

DO NOT:

- Take any additional medications or sedatives while you are taking your prescribed pain medication unless your doctor says it's okay.
- Take more medication than your doctor has prescribed, even if you still have some pain.
- Have your caregivers wake you to take pain medication or give you pain medication if you can't stay awake to eat or do daily activities.

| Medication name | Day | Time taken | When next dose can be taken | Pain level (Circle a number, 0 to 10, where "0" means "no pain" and "10" means "very severe" pain) |
|-----------------|-----|------------|-----------------------------|----------------------------------------------------------------------------------------------------|
| | | | | 0 1 2 3 4 5 6 7 8 9 10 |
| | | | | 0 1 2 3 4 5 6 7 8 9 10 |
| | | | | 0 1 2 3 4 5 6 7 8 9 10 |
| | | | | 0 1 2 3 4 5 6 7 8 9 10 |
| | | | | 0 1 2 3 4 5 6 7 8 9 10 |
| | | | | 0 1 2 3 4 5 6 7 8 9 10 |
| | | | | 0 1 2 3 4 5 6 7 8 9 10 |
| | | | | 0 1 2 3 4 5 6 7 8 9 10 |
| | | | | 0 1 2 3 4 5 6 7 8 9 10 |
| | | | | 0 1 2 3 4 5 6 7 8 9 10 |
| | | | | 0 1 2 3 4 5 6 7 8 9 10 |
| | | | | 0 1 2 3 4 5 6 7 8 9 10 |
| | | | | 0 1 2 3 4 5 6 7 8 9 10 |
| | | | | 0 1 2 3 4 5 6 7 8 9 10 |
| | | | | 0 1 2 3 4 5 6 7 8 9 10 |
| | | | | 0 1 2 3 4 5 6 7 8 9 10 |
| | | | | 0 1 2 3 4 5 6 7 8 9 10 |
| | | | | 0 1 2 3 4 5 6 7 8 9 10 |
| | | | | 0 1 2 3 4 5 6 7 8 9 10 |
| | | | | 0 1 2 3 4 5 6 7 8 9 10 |
| | | | | 0 1 2 3 4 5 6 7 8 9 10 |
| | | | | 0 1 2 3 4 5 6 7 8 9 10 |
| | | | | 0 1 2 3 4 5 6 7 8 9 10 |

Preventing complications

Nausea

Nausea can be a problem with any surgery. It can be caused by anesthesia or pain medication.

To prevent nausea:

- Alert your nurse when you are feeling nauseated. Nausea medication is generally available as ordered by your healthcare provider.
- Avoid taking pain medication on an empty stomach. While you may not feel like eating, it's important to refuel your body.
- Drink small amounts of 100% fruit juice or broth. Eat or drink something small every few hours.

Constipation

Constipation (cannot poop) is a common side effect of opioid medication. This is caused by opioids slowing down the movement of your bowels. About 6 out of every 10 people who take opioids after surgery have constipation.

It's important to prevent constipation after surgery so you do not have to go back to the hospital or to the emergency room. Follow the steps below and on the next page to help you stay regular while taking opioids. Continue to follow your bowel care plan until you are done taking opioids, you're having regular bowel movements without treatment, or if you get diarrhea.



Take stool softeners and laxatives as recommended by your doctor. Continue taking these as long as you are taking pain medication.



Add fiber to your diet. Eat more whole grains, fruits, vegetables, and nuts or take a fiber supplement. Add fiber slowly to prevent feeling bloated.



Walk. Exercise helps your colon be more active. Plus, it is important for your recovery.



Drink water. It is important to give your body the fluid it needs to prevent constipation.



Avoid foods that can cause constipation. Dairy products, bananas, white bread, white rice, and processed foods can all make the problem worse.

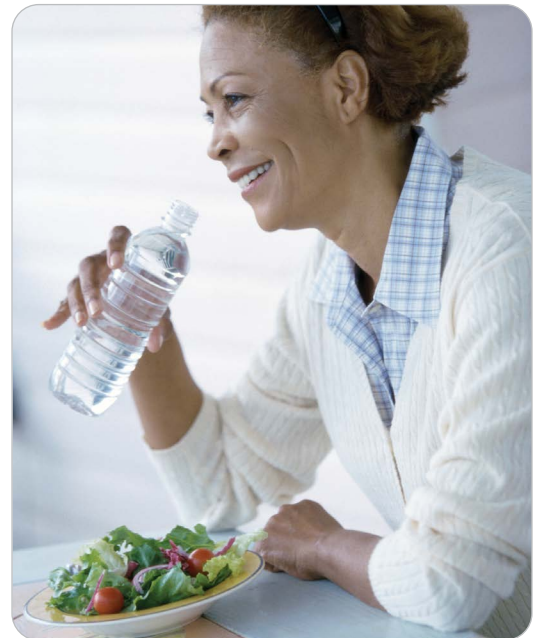

Getting things moving

Follow these steps to find relief and prevent constipation while taking opioids following surgery. The medications for constipation on this list are available over-the-counter at most drug or grocery stores.

STEP 1

GET THINGS MOVING

TAKE 1 capful or packet of **Miralax** (polyethylene glycol) mixed with at least 8 ounces of water or juice **2 times** daily, **AND/OR**

TAKE 1 tablet of **Senna-S** (sennosides / docusate) **2 times** daily.

- Once you are regular, you may adjust as needed (for example, stop Senna-S and continue Miralax).
- If you don't have a BM for a total of 3 days, move to Step 2.

STEP 2

KEEP THINGS MOVING

INCREASE Senna-S to **2** tablets **2 times** daily, **AND CONTINUE Miralax**, taking **1** capful or packet mixed with at least 8 ounces of water or juice **2 times** daily.

- Once you are regular, you may adjust as needed.
- If you don't have a BM for a total of 5 days, begin Step 3.

STEP 3

REALLY GET THINGS MOVING

ADD 1 dose (30 milliliters [ml]), of **Milk of Magnesia** (magnesium hydroxide).

- If you are able to have a BM, return to Step 2 until you are done using opioids or you have constipation or diarrhea. If you don't have a BM within 8 hours,

ADD 1 tablet (10 milligrams [mg]) of **Dulcolax** (bisacodyl) **OR** **1** rectal suppository.

- If you are able to have a BM, return to Step 2.
- If you don't have a BM,

TAKE another dose of **Milk of Magnesia** and **1** tablet of **Dulcolax**.

- If you are able to have a BM, return to Step 2.
- If you don't have a BM or have continued symptoms, move to Step 4.

STEP 4

REALLY, REALLY GET THINGS MOVING

Take $\frac{1}{2}$ to 1 bottle of magnesium citrate.

- Once you finally have a BM, return to Step 2
- If you don't have a BM while you are using opioids or symptoms of constipation continue, call your doctor.

Preventing complications (continued)

You will be asked to get up out of bed soon after your surgery. Movement and good pain management allow your mind and body to focus on healing and preventing possible complications.

Falls

After surgery, you are at a higher risk of falling. You may be attached to tripping hazards, such as IV lines, oxygen tubing and sensors, and compression boots. You may also have a nerve block which causes numbness in your limbs.

- **Do not get up without assistance.** Use your call light and only get up with the help of a caregiver. Notify your nurse if you can't use the call light.
- Use grab bars and assistive devices.
- Keep your walker, crutches, slippers, and other items you need within reach of your bed.
- Take your time! **Don't hurry** to answer the door or phone or wait too long to head for the bathroom.

Preventing infection

- Always wash your hands before changing a dressing.
- Keep the incision clean and dry.
- Follow your surgeon's instructions on how to clean the area and change the dressing.
- Follow your surgeon's instructions for showering, bathing, swimming, or using a hot tub.
- **Do not** allow pets on or around the wound until it is completely healed.

Breathing and lung problems

To prevent low oxygen levels and pneumonia, you will need to:

- Brush your teeth often to reduce the amount of bacteria in your mouth
- Cough and take deep breaths.
- Eat meals sitting up.
- Avoid using sleep medication unless it is approved by your doctor.
- Report any difficulty with breathing or awakening from sleep.
- Know the side effects of your medications. Opioid pain medications can slow your breathing.

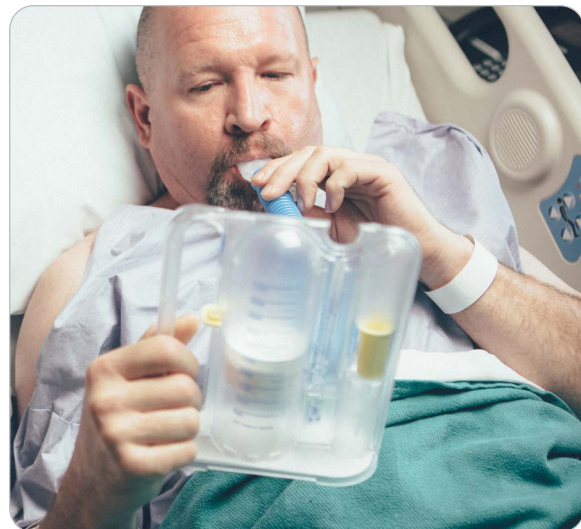

Blood clots

Blood needs to be pumped through the vessels in your legs to prevent blood clots or **deep vein thrombosis (DVT)**. To prevent blood clots from forming:

- Do your assigned exercises and if ordered by your surgeon use compression devices that are designed to help prevent clots.
- Walk as often as recommended.
- Take blood-thinning medications as prescribed.

How to prevent blood clots in your legs

The following exercises can be done to prevent blood clots from forming in your legs:

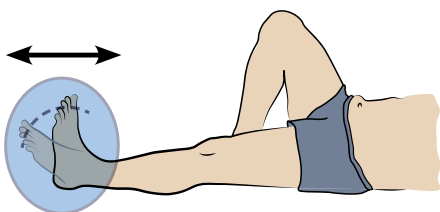

Ankle Pumps

- Point, then flex both feet.
- **Before surgery:** Do this exercise 10 to 15 times, 3 times a day.
- **After surgery:** Do this exercise 10 times an hour while awake.

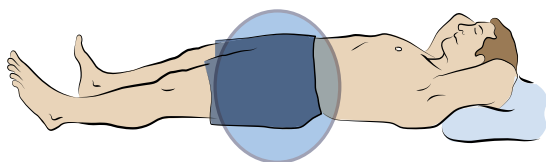

Gluteal [GLOO-tee-uhl] Squeezes

- Squeeze your buttock muscles together tightly. Your hips should rise slightly off the bed.
- Hold for 3 to 5 seconds, then release.
- **Before surgery:** Do this exercise 10 to 15 times, 3 times a day.

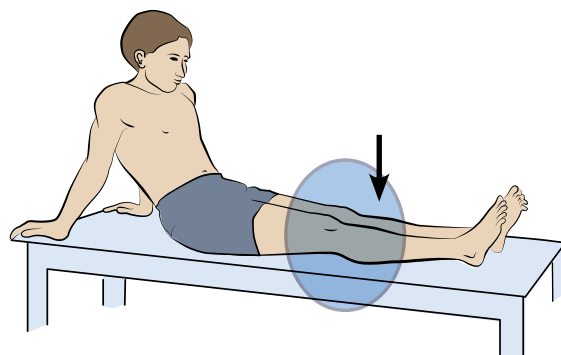

Quadriceps [KWOD-ruh-seps] Sets

- Lie in bed with your legs straight. Tighten the front thigh muscle of the leg that will undergo surgery while gently pressing your knee down toward the bed.
- Hold for 3 to 5 seconds, then relax the leg.
- **Before surgery:** Do this exercise 10 to 15 times, 3 times a day.
- **After surgery:** Do this exercise 10 times an hour while awake.

Physical and occupational therapy

You will need to take steps to protect yourself from falling and keep your new joint in safe positions while you heal. You will need to use assistive equipment to prevent falls and help you with tasks while you are recovering at home.

Physical and occupational therapy

The goal at Intermountain Health is to have you out of bed on the day of your surgery. The therapist will have you sit on the edge of the bed, move to a chair, walk in your room, or walk in the hallway. If you are having a shoulder surgery, the therapist will show you how to move your operative arm safely and how to take your sling on and off.

If you need to use stairs at home, the therapist will teach you how to go up and down them safely. Your partner in healing is encouraged to attend your physical therapy sessions.

An Occupational Therapist (OT) may check to make sure you can complete personal care activities (such as dressing, using the toilet, and showering) on your own. They will teach you how to use adaptive equipment safely for getting on and off the bed or toilet, and into and out of tubs and showers.

Your surgeon will recommend options for therapy after your surgery. Therapy may be done with a physical therapist in your home (home health) or at a therapy center (outpatient). Or your surgeon may have you follow their specific exercise handout without a physical therapist.



Protecting your new joint

To protect your new joint from dislocation or injury you will need to avoid certain arm or leg positions. Be sure to follow the instructions from your surgeon and therapist.

Hip

Avoid the following until your doctor or physical therapist say you may do so:

- Crossing your legs or ankles
- Kneeling down
- Turning (rotating) your legs inward or outward

Note: If you have a posterior approach hip replacement, avoid bending your hips past 90 degrees.

Knee

Do not rest for long periods of time with your leg bent at the knee or with pillows stuffed behind your knee. Rest with your leg straight and elevate it above the level of your heart with the pillows running from the lower part of your leg (calf) to your heel.

Shoulder

- Do not lift more than 5 pounds with your operative hand.
- Do not use your operative arm to lift, pull, or push weight. This includes pushing yourself up out of a chair or bed.
- Do not rotate your operative arm to reach up your back.

Reverse total shoulder replacement restrictions may vary depending on your surgery.

Assistive devices

Assistive devices are things that can help you get around safely and help you with daily tasks.

How to use a walker

Follow these safety guidelines to help keep you safe.

Standing up

Push up from your seat to a standing position—**don't use your walker to pull yourself up.**

Walking

- Make sure all 4 legs of the walker are on the ground before taking a step.
- Stand in the middle of the walker.
- Grasp the grips on each side of the walker with both hands.
- Push the walker forward at an arm's length that feels comfortable. The back legs of the walker should be even with your toes.
- Step forward with your weaker leg into the middle of the walker. Continue to grasp the walker grips with both hands.
- Step forward with your stronger leg. Keep weight off your weaker leg by supporting some of your weight with your arms.
- Work at keeping a good posture. Keep your elbows bent slightly, and don't lean forward over the walker.
- Keep an eye on what's ahead of you.
- To turn or change direction, you may need to lift the walker.
- Your physical therapist may adjust the walker to meet your particular needs.
- Always have at least part of your body inside the frame of the walker.
- **Do not use** your walker on stairs or an escalator.



How to use your forearm crutches

You may be given forearm crutches (also called “elbow crutches”).

Walking

Your weight should be on the crutches when moving your stronger leg. Be sure to support your weight on your hands. Then, follow this pattern:

- Lean on your stronger leg.
- Lean forward slightly, and move both crutches about a foot in front of you.
- Begin your step as if you were going to use the weaker leg, but instead, shift your weight to your crutches.
- Finish the step with your stronger leg.
- Focus on where you want to go, not on your feet.

Sitting down

Only sit in sturdy chairs. Make sure the seat is high enough that you won't have to fall into it. If necessary, add pillows. Then, do this:

- Back up to the chair.
- Hold your weaker leg a little bit in front of you, and put both crutches in the hand on the side of your stronger leg.
- Reach down with your free hand, and hold the arm or seat of the chair. Slowly lower yourself.
- Rest your crutches on their sides near your chair.

Standing up

- Slide yourself to the front of the chair.
- Hold both crutches in the hand on the side of your stronger leg.
- Put all your weight on the stronger leg, and push yourself up.



Going up and down stairs

When going up stairs, lead with your “good,” or stronger leg. When going down, lead with your “bad,” or weaker leg. To go up or down, start close to the stair and hold the handrail with one hand. In the other hand, hold both crutches:

- Use 1 crutch to support yourself.
- In the same hand as the supporting crutch, hold the other crutch horizontally with your fingers.

To go up stairs:

- Have someone walk behind you the first few times you climb the stairs.
- Keep the crutch on the step you're standing on. Then, step up with your stronger leg.
- Push down on the crutch, and step up with the weaker leg.
- When both feet are on the upper step, bring your crutch up.

To go down stairs:

- Have someone walk in front of you the first few times you go down the stairs.
- Put your crutch on the lower step.
- Bring your weaker leg down.
- Step down with your stronger leg.

If you don't feel steady, you may have to sit on each step and move up or down on your bottom. This may not be your favorite way to get around, but it can help you use the stairs safely and prevent a fall.

Forearm crutches

When standing up straight:

- The cuff should be about 1 to 2 inches below where your elbow bends.
- The handgrip should hit about where your wrist bends.

Use the buttons to adjust the length of the crutches.

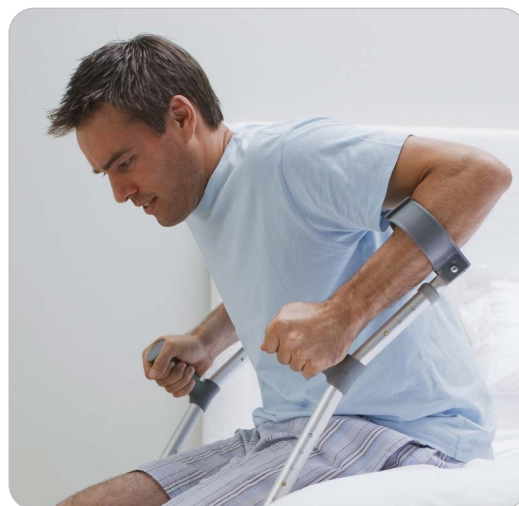
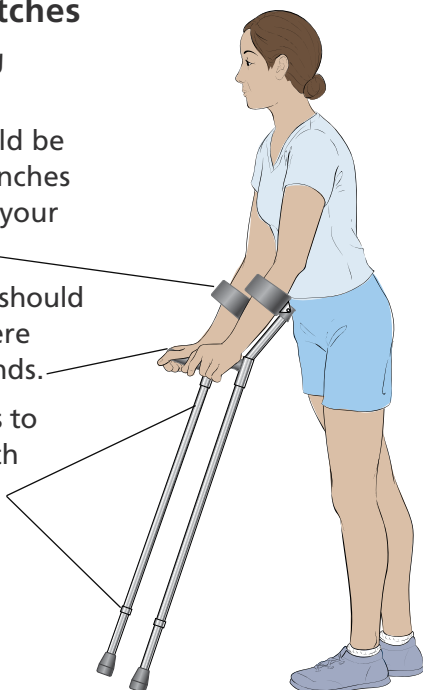

How to use your arm sling

Make sure the sling fits comfortably and snugly around the elbow. With the hand coming to the end of the sling.

Make sure that the end of the sling does not cut into the wrist or hand. This may mean it is too tight causing swelling, numbness, tingling or discoloration.

Ensure that the forearm is at a 90 degree angle. This helps to prevent blood and fluid pooling in your hand and wrist

Some slings have a strap that goes around the back. This prevents one from lifting the elbow away from the body.



For abduction pillow slings, wrap the pillow strap around the waist. Then attach the abduction pillow to the inside of the sling.

Preparing to go home

It is important to have a committed partner in healing long before your surgery. Your partner in healing should be able to stay with you for a few days after you go home. Talk to your family and friends about getting the support you need at home.

Getting ready to go home

Together, your care team will decide when it is safe for you to finish your recovery at home. Before you can go home, you must:

- Be medically healthy
- Have achieved your personal goals for discharge (see below)
- Have completed your home health arrangements, if needed
- Have a family member or partner in healing to take you home

When you have met this criteria, your surgeon will send you home with:

- Prescriptions for the medications you need. Some medications may be new to you, so be sure to ask any questions you have about them.
- Orders for home health or outpatient physical therapy based on the type of joint replacement you had and your individual needs.

Your nurse will meet with you to go over your home instructions, discuss your medications, and answer your questions.

Home health services may be prescribed if you:

- Are unable to leave home to go to outpatient physical therapy
- Go home with medications that require administration or monitoring.



My goals for when I go home

- Be able to get into and out of bed, up from a chair, into and out of the shower, and on and off the toilet without assistance
- Go up and down a flight of stairs safely
- Be able to get dressed and safely walk at least 150 feet on my own
- Be able to take my sling off and on by myself (shoulder surgery only)
- Perform my therapy exercises on my own or with help from my partner in healing
- Manage pain so that I can complete exercises and daily activities
- Eat and drink without difficulty
- Have necessary support and equipment at home

Intimacy after Surgery

Returning to sexuality

Most couples continue to have a satisfying sexual life after joint surgery. Here are some things to keep in mind:

- Ask your doctor when it is safe for you to have sex.
- Ask what safety measures you should follow. You may need to try new positions. Some positions are more comfortable and safer.

Give it time

Be patient with each other. Remember all the reasons you love each other, and remember all the other ways to stay connected.



Knowing when to call your doctor

It is important that you and your partner in healing or other caregivers know what to watch for as you recover and whom to call if needed.

What should I report to my surgeon?

- Difficulty waking up and or feeling very sleepy.
- Pain that gets worse or that you can't control with prescribed pain medication.
- No bowel movement within 7 days after surgery.
- Problems with your incision such as:
 - Unusual bleeding or new drainage (your dressing becomes soaked before it's time to change it)
 - Separation of the edges of the incision
 - Blood, pus, or a foul odor coming from the incision
- Numbness, tingling, or weakness in your arms or legs — or where you don't expect it.
- Any kind of fall.
- Itching.
- A fever that doesn't get better after taking medication. Follow the guidelines on your discharge order.
- Dizziness, light-headedness, or fainting.
- Skin rash.
- An unexpected ringing, buzzing, or whistling sound in your ears.
- Blurred vision.
- Persistent headache.
- Nausea when eating and drinking.
- Signs of deep vein thrombosis (blood clot), such as:
 - Pain in leg, calf, or foot
 - Leg swelling or tenderness
 - Warm skin

What should I report to my primary care physician?

- Concerns about regular medications such as those you take for high blood pressure, diabetes, or heart conditions.
- Symptoms of a urinary tract infection, such as feeling like you need to urinate (pee) frequently, difficulty or pain when urinating, blood in the urine, pelvic or back pain, or fever.
- Trouble controlling your blood sugar (if you have diabetes).

Before you go to the emergency room, have you contacted your surgeon?

Go to the emergency room or call 911 if you have:

- **Difficulty breathing or shortness of breath**
- **Chest pain**
- **Black or bloody stool**
- **Bloody vomit**
- **Stroke symptoms** (loss of balance, loss of ability to move one side of your body, facial droop, slurred speech)
- **Suspected overdose**

Medication tracker

| Medication name | Day | Time taken | When next dose can be taken | Pain level (Circle a number, 0 to 10, where "0" means "no pain" and "10" means "very severe" pain) |
|-----------------|-----|------------|-----------------------------|----------------------------------------------------------------------------------------------------|
| | | | | 0 1 2 3 4 5 6 7 8 9 10 |
| | | | | 0 1 2 3 4 5 6 7 8 9 10 |
| | | | | 0 1 2 3 4 5 6 7 8 9 10 |
| | | | | 0 1 2 3 4 5 6 7 8 9 10 |
| | | | | 0 1 2 3 4 5 6 7 8 9 10 |
| | | | | 0 1 2 3 4 5 6 7 8 9 10 |
| | | | | 0 1 2 3 4 5 6 7 8 9 10 |
| | | | | 0 1 2 3 4 5 6 7 8 9 10 |
| | | | | 0 1 2 3 4 5 6 7 8 9 10 |
| | | | | 0 1 2 3 4 5 6 7 8 9 10 |
| | | | | 0 1 2 3 4 5 6 7 8 9 10 |
| | | | | 0 1 2 3 4 5 6 7 8 9 10 |
| | | | | 0 1 2 3 4 5 6 7 8 9 10 |
| | | | | 0 1 2 3 4 5 6 7 8 9 10 |
| | | | | 0 1 2 3 4 5 6 7 8 9 10 |
| | | | | 0 1 2 3 4 5 6 7 8 9 10 |
| | | | | 0 1 2 3 4 5 6 7 8 9 10 |
| | | | | 0 1 2 3 4 5 6 7 8 9 10 |
| | | | | 0 1 2 3 4 5 6 7 8 9 10 |
| | | | | 0 1 2 3 4 5 6 7 8 9 10 |
| | | | | 0 1 2 3 4 5 6 7 8 9 10 |
| | | | | 0 1 2 3 4 5 6 7 8 9 10 |
| | | | | 0 1 2 3 4 5 6 7 8 9 10 |
| | | | | 0 1 2 3 4 5 6 7 8 9 10 |
| | | | | 0 1 2 3 4 5 6 7 8 9 10 |
| | | | | 0 1 2 3 4 5 6 7 8 9 10 |
| | | | | 0 1 2 3 4 5 6 7 8 9 10 |
| | | | | 0 1 2 3 4 5 6 7 8 9 10 |
| | | | | 0 1 2 3 4 5 6 7 8 9 10 |
| | | | | 0 1 2 3 4 5 6 7 8 9 10 |
| | | | | 0 1 2 3 4 5 6 7 8 9 10 |
| | | | | 0 1 2 3 4 5 6 7 8 9 10 |
| | | | | 0 1 2 3 4 5 6 7 8 9 10 |
| | | | | 0 1 2 3 4 5 6 7 8 9 10 |
| | | | | 0 1 2 3 4 5 6 7 8 9 10 |
| | | | | 0 1 2 3 4 5 6 7 8 9 10 |

Survey notice

Thank you for scheduling your joint replacement surgery. A few days before your surgery, you can expect to receive an email or text message with a request to complete a survey within 2 days of your surgery. The survey will tell your doctor how you have been feeling and how well you get around. *(If you receive an email **and** a text, you only need to do the survey once.)*

If you answer the survey right away, you won't get any additional messages. If you don't answer the survey, you will get 2 more reminders.

Example: Notable Text Survey

Greetings from [Your Surgeon] and the American Joint Replacement Registry (AJRR)

At your last visit with your orthopedic doctor and/or hospital or surgery center, someone from your medical team talked to you about completing a survey that asks about your joint problems and health.

EACH SURVEY SHOULD ONLY TAKE 5 to 10 MINUTES TO COMPLETE.

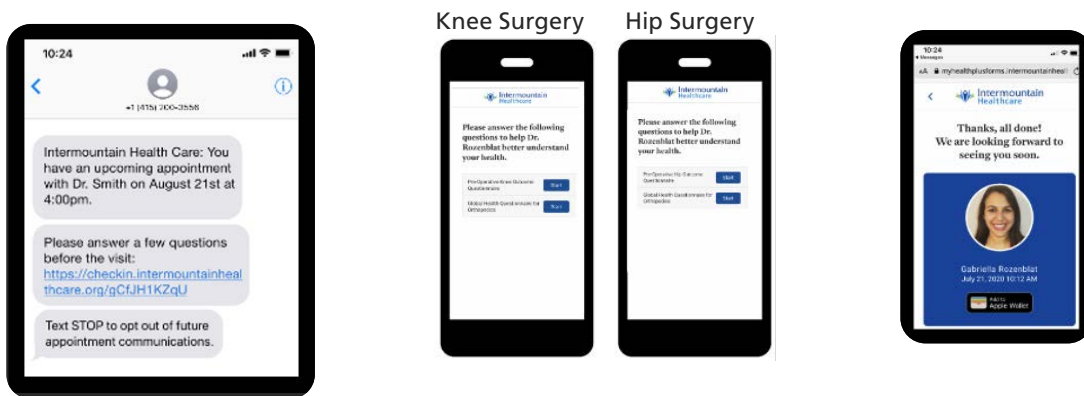

Your care team will be checking in with you after your surgery to ensure that you are making progress. You will receive this same survey several times after your surgery.

By completing these surveys your care team can understand how well you have recovered following surgery.

To find this booklet and other patient education, go to:
intermountainhealthcare.org



Intermountain Healthcare complies with applicable federal civil rights laws and does not discriminate on the basis of race, color, national origin, age, disability, or sex. Se proveen servicios de interpretación gratis. Hable con un empleado para solicitarlo. 我們將根據您的需求提供免費的口譯服務。請找尋工作人員協助。

©2016–2023 Intermountain Healthcare. All rights reserved.

The content presented here is for your information only. It is not a substitute for professional medical advice, and it should not be used to diagnose or treat a health problem or disease. Please consult your healthcare provider if you have any questions or concerns. More health information is available at: intermountainhealthcare.org/health-information/health-library.

Patient and Provider Publications MSK005–03/23